



Martensite and magnetic domain structure in ferromagnetic shape memory single- and polycrystals

R.M. Grechishkin^{a,*}, T.A. Lograsso^b, D.L.Schlagel^b, V.V. Koledov^c, A.B. Zalyotov^c,
S.A. Chigirinsky^c

^aTver state University, 170000 Tver, Russia

^bDepartment of Science and Engineering, Ames Laboratory, Iowa State University, Ames IA 50011, USA

^cInstitute of Radioengineering and Electronics of RAS, 125009 Moscow

Abstract

Magnetic shape memory effect observed in a number of materials is based on the coexistence and cooperation of closely correlated ensembles of martensite and magnetic domains. In the present work we describe the results of an experimental study of the domain structure (DS) of poly- and single crystals of ferromagnetic Co-Ni-Ga and Ni-Mn-Ga Heusler alloys making use of a number of optical techniques including magneto-optical imaging films (MOIF), interference and digital differential microscopy.

© MISM2005. All rights reserved

PACS: 75.30.Cc; 75.80.+q; 81.30.Kf

Keywords: Ferromagnetic shape memory alloys; Martensite structure; Magnetic domain structure; Magneto-optical imaging

1. Introduction

Magnetically controlled strain in ferromagnetic shape memory alloys (FSMA) of the Ni₂MnGa type is based on the reorientation of the twin structure of martensite under applied magnetic field [1-3]. Physical properties and possible applications of these alloys were actively studied during the last decade [4]. However the utilization of FSMA requires refined understanding of material behaviour, and particularly more detailed knowledge of the relations between coexisting and cooperating ensembles of ferromagnetic and martensitic domains.

The development of adequate quantitative theory

of the interaction between martensitic and magnetic domain walls in real materials containing different crystal imperfections is a difficult problem. Its solution is restrained by the scarcity of necessary experimental data. Some results of the DS studies of FSMA obtained mainly by electron microscopy were reviewed recently by Y. Ge with co-authors [5] and O. Heczko [6]. In the present work we focus our attention on the experimental examination of the martensite and magnetic DS in Ni-Mn-Ga and Co-Ni-Ga alloys with the emphasis on the possibilities of optical methods.

* Corresponding author. Tel.: 0822-34-42-15; fax: 0822-32-17-32. E-mail address: rostislav.grechishkin@tversu.ru

2. Experimental

Polycrystalline Ni-Mn-Ga and Co-Ni-Ga alloys were prepared by arc melting in pure argon. The samples were homogenized for 100 hours at 800°C and water quenched. Single crystals were prepared by the Bridgman method described in detail elsewhere [7]. All samples were checked by X-ray analysis. The characteristic temperatures of austenite-martensite transitions and Curie points were determined from the temperature variation of the AC susceptibility.

All optical work was performed on a standard metallographic microscope refashioned to provide two-channel differential digital mode of observation in polarized light [8].

3. Observation of martensite domain structure

Unusual behaviour of the materials under study may be noticed during preparation of metallographic sections. Flat polished surfaces prepared on austenite samples acquire clearly pronounced relief after A→M transition into the martensite state. This relief delineates the martensite structure which may be observed by naked eye (Fig. 1) or in the microscope under ordinary bright light illumination. Repeated heating (M→A) restores flatness. However if flat surface is prepared on martensite samples it is not restored after M→A→M cycle.

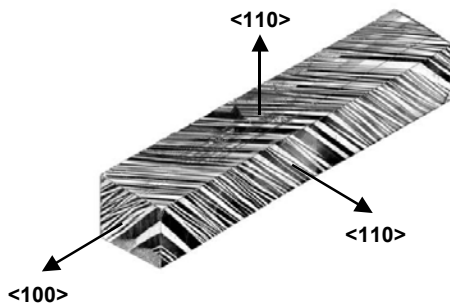

Fig. 1. Bright field image of the martensite relief of oriented $\text{Co}_{48}\text{Ni}_{22}\text{Ga}_{30}$ single crystal. Sample size $3 \times 3 \times 15$ mm.

The parameters of this relief may be measured with the aid of interference microscopy (Fig. 2). Interference fringe curvature provides information on

the surface microrelief, while the distance between the $\lambda/2$ interference bands of equal width characterizes the surface local inclination.



Fig. 2. Interference image of the polysynthetic twin structure on the (110) plane of $\text{Co}_{48}\text{Ni}_{22}\text{Ga}_{30}$ single crystal. $\times 140$

Combination of deformation measurements with microstructural observations provides local information on the details of martensite variants behaviour during phase transitions (Fig. 3).

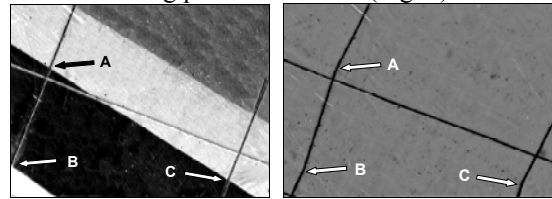

Fig. 3. Microstructure of $\text{Ni}_{2.16}\text{Mn}_{0.84}\text{Ga}$ at RT (martensite, left) and at $T = 370$ K (austenite, right) showing the deformation of initially rectangular diamond scratched reference grid. $\times 60$ Observations in polarized light provide another way of the analysis of martensite structure. In this case optical contrast originates from anisotropic reflectance [9] of the martensite phase and depends on the orientation of the c -axis with respect to the plane of light polarization. Fig. 4 demonstrates the dependence of the polarized light intensity reflected from adjacent martensite variants on the specimen angular position. It is seen that the optical contrast $C = (I_1 - I_2) / (I_1 + I_2)$ may be set to zero, be maximized or inverted by rotation of the sample on the microscope specimen stage. This specific feature helps to differentiate the images of martensite structure from those of magnetic domains revealed by Kerr effects.

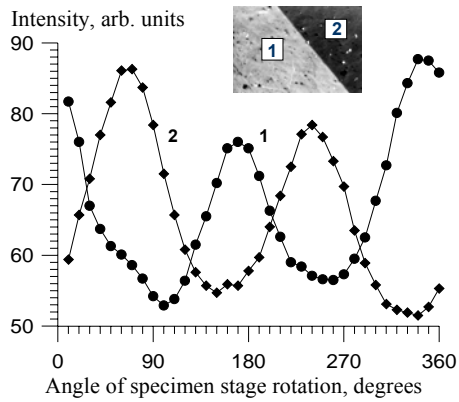

Fig. 4. Angular variation of the reflected light intensity for a $\text{Ni}_{2.16}\text{Mn}_{0.84}\text{Ga}$ sample. Curves 1 and 2 correspond to local measurements for variants 1 and 2. Curves intersections correspond to the condition of zero contrast between the variants.

4. Magnetic DS observation with the aid of MOIF

It is well known that in ferromagnetic samples diversified surface DS occur in addition to main domains in order to minimize the magnetostatic stray fields when the magnetization \mathbf{M} is not parallel to the sample surface. This surface DS of incidental interest disguises the structure of main domains important for the understanding of material behaviour.

MOIF with mirror precoat, which were already successfully applied in the study of FSMA [10, 11], provide an interesting possibility of minimizing the camouflaging effect of secondary domains. To this end the MOIF is mounted on a gadget enabling to finely regulate the distance to the sample surface from zero to several tens of μm . At some selected distance the short-range stray fields from surface domains become negligibly small while the long-range fields from large main domains stay large enough to produce the image in the MOIF [12, 13].

Shown in Fig. 5 is 3D view of magnetic 180° degree macrodomains on the $\{100\}$ planes of $\text{Ni}_{2.3}\text{Mn}_{1.4}\text{Ga}$ single crystal obtained with the aid of MOIF. The observed macrodomains are running through the whole sample. Surface DS, as well as 90° modulation of \mathbf{M} direction by martensite plates inside macrodomains in this case are out of vision.

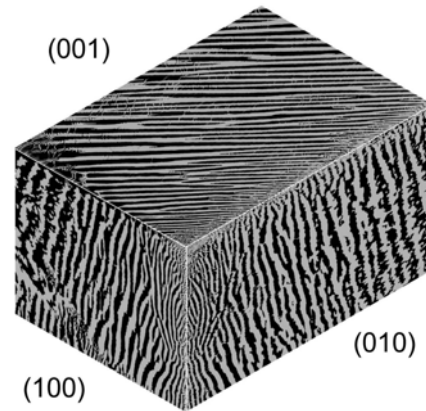

Fig. 5. 3D view of magnetic 180° macrodomains on the $\{100\}$ planes of an oriented $\text{Ni}_{49}\text{Mn}_{29.7}\text{Ga}_{21.3}$ single crystal having dimensions of $1.2 \times 1.5 \times 2.5$ mm.

The above features are useful for quick inspection of the macro- and microstructure of ingots and estimation of the quality of single crystals.

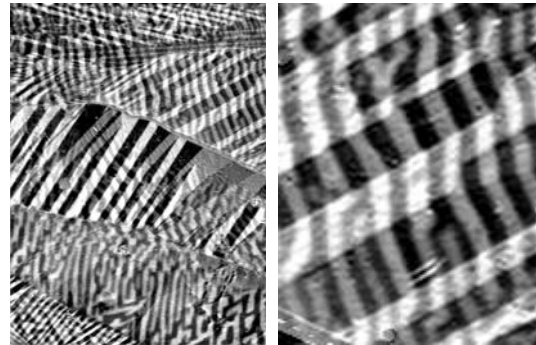

Fig. 6. Simultaneous observation of martensite and magnetic DS of polycrystalline textured $\text{Ni}_{2.16}\text{Mn}_{0.84}\text{Ga}$ ingot. Left image - $\times 50$; right image - enlarged fragment of the left one.

Fig. 6 demonstrates an example of simultaneous observation of martensite and magnetic DS of polycrystalline sample. This was made possible making use of transparent MOIF without the Al mirror precoat in such a way that, in addition to the magnetic image, martensite image is formed by the light transmitted back and forth through the MOIF. It is seen from Fig. 6 that in spite of the sacrifice of magnetic image intensity owing to the mirror removal the Faraday contrast still remains high enough for adequate observations. The enlarged

fragment shows the inner structure of magnetic macrodomains modulated by martensite plates.

5. Conclusion: scheme of the DS in martensite state

Fig. 7 shows the basic scheme of the martensite twins and main magnetic domains. Arrows show the direction of magnetization vectors \mathbf{M} , while + and - signs indicate the appearance of magnetic poles.

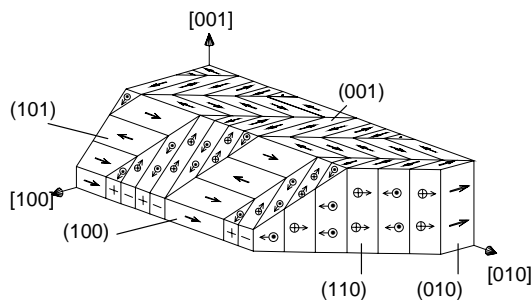

Fig. 7. Scheme of the magnetic substructure of martensite domains on different crystallographic planes

From symmetry considerations only 180° magnetic domains may exist in twin plates because martensite possesses uniaxial magnetic anisotropy. Vector \mathbf{M} is oriented along easy c -axes at angles of $\pm 45^\circ$ with respect to the twin boundaries. Due to magnetostatic coupling the 180° magnetic domains of neighbouring twins cooperate with each other forming continuous macrodomains running through the whole crystallite or single crystal sample and changing the direction of \mathbf{M} by $\pm 90^\circ$ in a zigzag fashion at each intersection of the twin boundary.

There is no experimental evidence of magnetic charges appearing at the intersection of magnetic domains with martensite boundaries, so it may be assumed that the 90° magnetization rotation at the twin wall is of the Bloch type [14], i.e. the normal component of the \mathbf{M} vector remains constant during the 90° transition. Correspondingly the surface energy of the 90° Bloch wall bounded with the twin wall will be $\gamma_{90^\circ} = \gamma_{180^\circ} / 2 = 2\sqrt{AK_1}$ in usual notation.

The configuration of the domain walls on the

sample surfaces depends on their crystallographic orientation and may be predicted from simple geometric considerations. The (001) plane is free of charges (Fig. 7); domain walls are oriented at $\varphi_{1,2} = \pm 45^\circ$ with respect to the twin traces as demonstrated experimentally in [5, 6]. For other planes these angles are different and are not necessary symmetric with respect to the twin trace on the surface (cf. Fig. 6). On (100) plane for odd twins $\mathbf{M} \parallel (100)$, while for even ones $\mathbf{M} \perp (100)$, so in the latter case well-known surface subsidiary DS typical of uniaxial materials [12-14] should appear to minimize the stray fields. Various other combinations occur for arbitrary planes of observation.

In summary, the present study confirms the complicated character of relations between martensite and magnetic DS in FSMA. It is demonstrated that the combination of various mutually complementary optical methods is useful in the study of these relations. The versatility of optical methods is especially important in performing experiments under the action of external factors which are in progress.

The challenge is to image processes of martensite and magnetic DS interaction in real time under the influence of static and dynamic external mechanical stresses, magnetic field and temperature variation.

References

- [1] K. Ullakko, J.K. Huang, C. Kantner, R.C. O'Handley, V.V. Kokorin, *Appl. Phys. Lett.* 69 (1996) 1966.
- [2] R.C. O'Handley, *J. Appl. Phys.* 83 (1998) 3263.
- [3] R.D. James, M. Wuttig, *Phil. Mag. A* 77 (1998) 1273.
- [4] A.N. Vasil'ev, V.D. Buchel'nikov, T. Takagi, V.V. Khovailo, E.I. Estrin, *Phys. Usp.* 46 (2003) 559.
- [5] Y. Ge, O. Heczko, O. Soderberg, V.K. Lindroos, *J. Appl. Phys.* 96 (2004) 2159.
- [6] O. Heczko, *J. Magn. Magn. Mater.* 290-291 (2005) 787.
- [7] D.L. Schlagel, Y.L. Wu, W. Zhang, T.A. Lograsso, *J. Alloy Comp.* 312 (2000) 77.
- [8] O.M. Korpusov, R.M. Grechishkin, T. Breczko, M.Yu. Goosev, N.S. Neustroev, *Proc. SPIE* 5127 (2003) 140.
- [9] N.I. Vlasova, N.N. Schegoleva, G.S. Kandaurova, *Fiz. Met. Met.* 8 (1992) 110.
- [10] A. Sozinov, Y. Ezer, G. Kimmel, D. Giller, Y. Wolfus, Y. Yeshurin, K. Ullakko, V.K. Lindroos, *J. Phys. IV (France)* 11 (2001) Pr8-311.
- [11] O.M. Korpusov, R.M. Grechishkin, V.V. Koledov, V.V. Khovailo, T. Takagi, V.G. Shavrov, *J. Magn. Magn. Mater.* 272-276 (2004) 2035.

- [12] R.M. Grechishkin, M.Yu. Goosev, S.E. Ilyashenko,
N.S. Neustroev, *J. Magn. Magn. Mater.* 157/158, 305 (1996).
- [13] M.Yu. Goosev, R.M. Grechishkin, Yu.F. Kozlov,
N.S. Neustroev, *Izv. Vuzov. Elektron.tekhn.* 1 (2000) 124.
- [14] R.C. O'Handley, *Modern Magnetic Materials: Principles and
Applications*, Wiley Interscience, 1999.